

# 1. CONTENTS

---

1. Contents .....	1
2. Control Location .....	3
3. Before Riding .....	4
4. Safe Riding .....	5
5. Riding .....	6
6. Use Genuine Spare Parts .....	6
7. Use of Each Component .....	7
Gauges .....	7
Operation of Ignition Switch .....	8
Use of Buttons .....	9
Safety Helmet Hook .....	10
Seat Lock .....	10
Luggage Box .....	10
Fuel Tank Cap .....	11
Brake .....	11
8. Important Points and Cautions for Starting Engine .....	12
9. The Best Way to Ride off .....	13
The Control of Throttle Valve Handle .....	13
Parking Method .....	13
10. Inspection and Maintenance before Riding .....	14
Routine Inspection .....	14
Engine Oil Inspection and Change .....	14
Inspection of Fuel level.....	15
Transmission Oil Inspection and Change .....	15
Inspection and Adjustment of Brake Free Play .....	16
Disk Brake Inspection .....	17
Throttle Valve Handle Clearance Adjustment.....	18
Tire Inspection .....	18
Steering Handle Front Shock Absorbers Inspection .....	19
Rear cushion hardness setting .....	19
Checking for Fuel Leakage .....	19
Checking the Lubrication of Body's Various Mechanisms .....	19
Inspection and Maintenance of Battery .....	20
Checking and Changing Fuses .....	21

# 1. CONTENTS

---

Checking the Turn Signal Lights and Horn .....	21
Checking the Headlight and Tail Lights .....	21
Checking the Brake Light .....	22
Checking the Spark Plug .....	22
A reference table for anti-freeze concentration percentages under different temperatures.....	22
Cooling system inspection.....	23
Replenishment of coolant.....	23
Checking the Air Cleaner .....	24
11. When there is an Abnormal Condition or a Trouble .....	25
Diagnosis when Engine does not Start .....	25
12. C.D.I. Electrical Ignition System .....	25
13. Suggestions on Engine Fuel .....	25
14. Transmission Oil .....	25
15. Cautions for Riding Motorcycle .....	26
16. Periodical Maintenance Schedule .....	27
17. Specification .....	28

## 2. CONTROL LOCATION

---

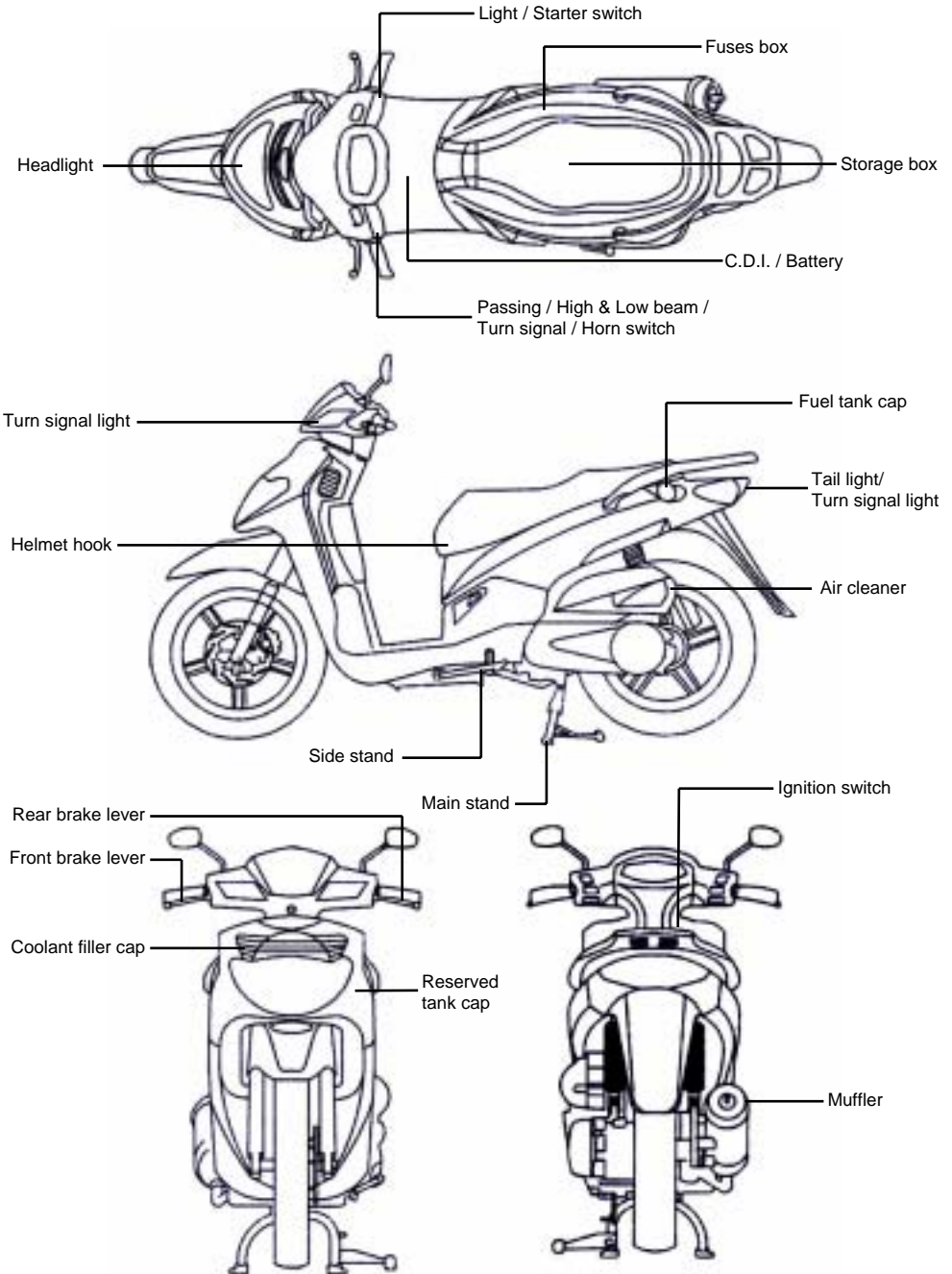

### 3. BEFORE RIDING

---

This manual describes the correct usage of this scooter including safety precautions to ensure your personal safety while operating this scooter.

Please read this manual carefully and completely before operating this scooter. Familiar yourself with these precautionary measures before you start riding. Do not attempt to operate this scooter until you have attained adequate knowledge of its controls and operating features and have received adequate training in safety and proper riding techniques.

**Thank you very much for choosing a SANYANG scooter:**

- In order to maximize your scooter's performance, a periodic inspections and regular maintenance should be performed. We recommend that after riding your new scooter for the first 300 kilometers that you take your scooter to an Authorized SANYANG scooter dealer for an inspection. Thereafter, we recommend that you take your scooter to an Authorized SANYANG scooter dealer for an inspection every 1000 kilometers.
- In case the scooter's specifications and construction are modified and different from the photos and diagrams on the owner's manual/catalogues, the specifications and construction of the actual scooter shall prevail.

## 4. SAFE RIDING

---

It is very important to be alert and wear proper clothing when operating this scooter. Observe all traffic regulations and signs, do not rush, and always ride carefully and obey all traffic signs and signals. Usually, most people would ride their newly bought scooter very carefully, but after they became familiar with their scooter, they tended to become reckless which may result in an accident.

### **To remind you:**

- Always wear a helmet when riding your scooter. Use care to properly tighten the chin strap. Never operate this scooter with a helmet hanging from the scooter. It may get caught on something causing you to lose your balance. Protective clothing, gloves and goggles or other protective eye wear is highly recommended.
- Wear close fitting clothes. Open or loose clothing may be blown by the wind and cause clothing to get caught on the steering handle or other scooter parts and could affect riding safety.
- Hold the steering handle with both hands when riding. Never ride with only one hand. Keep both feet on the foot rests.
- Always observe the speed limit and obey all other traffic signs and signals.
- Check to see that your scooter is road worthy before operating.
- If you notice any irregularities with the scooter before driving, make all necessary repairs before resuming its operation.

### **WARNING!!**

- While riding, the exhaust muffler is extremely hot. A passenger must use care and place his/her feet on the foot pegs to avoid being burned by the exhaust muffler. Do not touch any part of the exhaust system while it is hot. Failure to follow this instruction could result in being burned.
- After riding, the exhaust muffler is extremely hot and remains hot for a while even after the engine has been switched off. Be careful not to get burned when conducting an inspection or maintenance of the scooter. Do not touch any part of the exhaust system while the same is hot. Touching any part of the exhaust system while hot could result in being burned.
- After riding, the exhaust muffler is extremely hot. Select a suitable location to park your scooter to help others avoid getting burned by the exhaust muffler.
- Only wear clothing that fully covers your legs, ankles and feet to avoid having your legs from being burned by any part of the exhaust system, including the exhaust muffler. The same applies to any passenger riding with you.

### **WARNING:**

- Do not modify your scooter! Modification to this scooter, removal of original parts, or fitting of non-authorized part from SANYANG and/or accessories may render the scooter unsafe and illegal to operate. Modifying the scooter will void the warranty. Modifying the scooter may be illegal. Modification will affect the performance of the scooter. Engine modification could cause poor engine performance, engine damage, excessive exhaust noise, and could shorten the life of the scooter. The installation of any performance increasing components results in the loss of this warranty.

## 5. RIDING

---

- Operation of the scooter must be only by a person with a valid license to operate the same.
- Your safety on the road relates to the way you drive. Never operate this scooter when tired, under the influence of alcohol, drugs or medication.
- Rider's posture will greatly affect riding safety. Always keep your body's gravity in the center of the seat, if your body's gravity is on the rear part of saddle, the front wheel load will be reduced, and this will cause the steering handle shaking. Keep the related parts of your body such as arms, palms, lumbar, and toes relax and ride with the most comfortable posture in order to be able to react quickly whenever it is necessary. It is dangerous to ride a scooter with an unstable handle.
- It will be much easier to make a turn if rider inclines his body inward when turning. On the other hand, the rider will feel unstable if his body and the scooter do not incline.
- The scooter is hard to control on a bumpy, unleveled, unpaved road, try to know the road conditions in advance, slow down and use your shoulder's force to control the handle. Always adjust your speed to the road and traffic condition.
- Suggestion: Do not load objects on the front pedals unnecessarily, to avoid affecting the riding safety and the operation of steering handle.

### **WARNING:**

- Be aware of the weight load on the scooter. The scooter will handle different depending on its load. Over loading the scooter will cause the scooter to become unstable and hard to maneuver, as it may change the center of gravity, which could result in an accident that could cause injury or death. Do not exceed the maximum authorized load.

### **WARNING:**

- Only carry cargo or luggage in/on places that are specifically designed for carrying cargo or luggage.
- Do not place flammable objects, such as rags, paper, plastic, etc. or other objects between body covers and the engine. Placing objects in these areas could cause a fire or other damage to the scooter, and serious injury as a result there from.

### **Suggestion:**

To maximize the scooter's performance and prolong its life:

- The first month or first 1000km is the wear- in period for the engine and components. Avoid rapid acceleration, and keep the speed below 60km/hr.

## 6. USE GENUINE SPARE PARTS

---

In order to maintain the scooter's best performance, each part's quality, material, and machined precision must conform with the design requirements. **"SYM Genuine Spare Parts"** were made from the same high quality materials used for the original scooter. No parts would be sold to the market until they could meet the designed specifications through sophisticated engineering and stringent quality control. Therefore, it is necessary to purchase **"SYM Genuine Spare Parts"** from **"SYM Authorized Dealers or Franchised Dealers"** when replacing spare parts. If you buy cheap, or fake substitute parts from the market, no guarantee can be provided either for the quality or durability thereof. Also, it may result in unexpected troubles and lower the scooter's performance.

- Always use **SYM Genuine Spare Parts** to keep your scooter pure blood and to ensure its long service life.

## 7. USE OF EACH COMPONENT

### Gauges

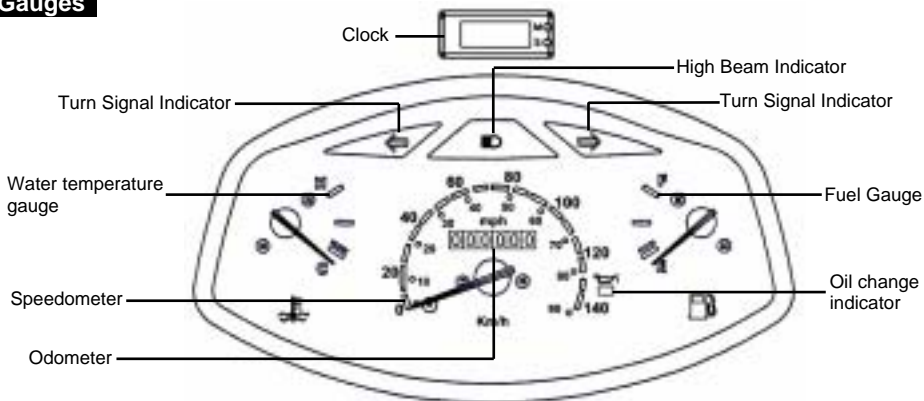

#### CAUTION:

- Do not wipe plastic components, such as the instrument panel, the headlight, body covers, etc. with solvents, such as gasoline, etc. Wiping plastic components with solvents can damage these components.

#### • **Speedometer:**

This shows your speed in kilometers per hour (km/h) and in mileage per hour (mph).

#### • **Odometer:**

This odometer shows the total kilometers this motor has been driven.

#### • **Turn Signal Indicator:**

The left or right Indicator will be flashing according to the operated directions of turn signal light switch when it is turned on.

#### • **High Beam Indicator:**

This indicator comes on when the high beam headlight switch is turned on.

#### • **Fuel Gauge:**

The pointer in this gauge shows how much fuel remains in the tank.

The pointer stays in "E" position when key switch is turned to "OFF."

When key switch is turned to "ON", and the "pointer" also in "E" position (red area).

Refuel immediately.

#### • **Water temperature gauge:**

To indicate engine coolant temperature.

When the main switch turns to "ON", the pointer indicator should be below the (H) position when the scooter is operating.

If the pointer indicator stays above (H) position. Please check the coolant level of spare coolant tank and check cooling fan for proper operation.

#### CAUTION:

The indicator will stay above (H) position when engine is run under high temperature for a long period of time. In this case, the only way to cool the engine is to stop the engine.

## 7. USE OF EACH COMPONENT

### • Engine Oil Change Indicator:

This indicator shows when to change engine oil by colors. Usually, the indicator will be in green. But it will be in red color when the scooter has been ridden approximately 1,000 km. Then, it means you should add or change the engine oil. After replacing the engine oil, please insert the key into the relief hole as shown on the right. The indicator will then turn from red to green.

#### Zero reset button

1. Operate the zero reset button regularly.
2. To reset to zero, simply press the button. The button will spring back to its original position when released.

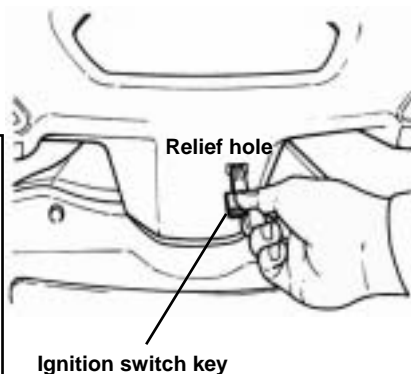

#### CAUTION:

- The indicator will remain in green when engine oil has been changed after the first 300km. Insert the key into relief hole even the indicator is in green color. If not, the kilometers for engine oil change will not be accurate.
- It is necessary to insert the key into the relief hole as far as it can go to turn the indicator to green color.

### • Clock: (Set time in 24 hour mode)

"M" – mode bottom: Press the "M" bottom, the clock order shows "Time mode", "Hour setting mode", "Minute setting mode", "Second setting mode". Final back to the "time mode".

"S" – set bottom: At "Hour setting mode" or "Minute setting mode" or "Second setting mode". Press the "S" bottom once, numerical can be increase. If keeping on pressing for 2 seconds can accelerate the adjustment. Until to set free the bottom. (At "Second setting mode", the colon ":" in the center will be flash for 1 seconds.

## OPERATION OF IGNITION SWITCH

### "ON" position:

- Engine can be started in this position.
- Ignition switch key can not be removed.

### "OFF" position:

- Engine is shut off and can not be started in this position.
- Ignition switch key can be removed.

### "LOCK" position:

- Turn the handle all the way to left, then press down the key and turn the key to the "LOCK" position on the left.
- In this position, the handle is locked and the key can be removed.
- To unlock, simply turn the key from "LOCK" to "OFF".



IGNITION SWITCH

#### CAUTION:

- Never turn the ignition switch key when the scooter is running. Turning the key to either "OFF" or "LOCK" position will shut off the electrical system and could result in loss of control or an accident.
- Only turn the ignition switch key to the "OFF" or "LOCK" position after the scooter has been completely stopped.
- If the ignition switch key remains in the "ON" position for a prolonged period after the engine has been stopped, the battery capacity will be reduced and this may affect the engines ability to start.
- Lock the steering handle and remove the key before leaving the scooter. Do not leave the key in the ignition switch when leaving the scooter.

## 7. USE OF EACH COMPONENT

### USE OF BUTTONS

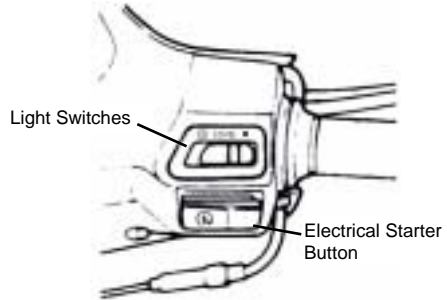
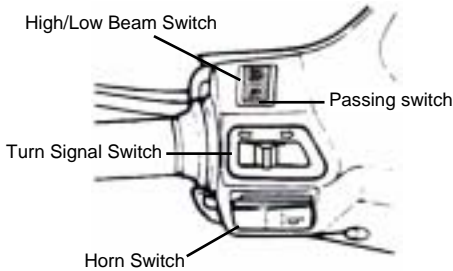

#### • Light switches



When the switch is turned to this position as the engine is being started, headlight, rear light, instrument panel light, and position light will come on.



When the switch is turned to this position as the engine is being started, rear light, instrument panel light, and position light will come on.



When the switch is turned to this position, all lights will go off.

#### • Electrical Starter Button



This is a starting motor button (switch) for engine starting.

With the main switch "ON", press this button while holding the front or rear brake lever will start the engine.

#### Note:

- Position Light Function:  
This light can indicate the motorcycle's position when the motorcycle is running in dim, rainy, or foggy weather.



#### CAUTION:

- Release this button immediately after engine has been started, and never press the button again to avoid damaging the engine.
- This mechanism is a safety design. The engine can only be started after the front or rear brake lever (pedal) has been applied.
- Do not use light system. Turn headlight and turn signal lights to the "OFF" position when the engine is being started.

#### • High/Low Beam Switch

This is the high and low beam of headlight switching switch. Press this switch to switch between high and low beams.



This is for high beam.



This is for low beam. (Please turn to low beam when riding in city)

#### • Passing Switch

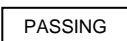

Turn ignition switch "ON" and press this button down. Then, the high beam of headlight will come on immediately to warn the driver of the vehicle ahead that you intend to overtake him/her. (For overtaking, high beam indicator will come on at this time) This button will return to original position after releasing.

## 7. USE OF EACH COMPONENT

### • Horn Switch



Press this button down when ignition switch is in the "ON" position to sound the horn.

#### NOTICE:

- Do not press the horn button when you are in the no horn area.

### • Turn Signal Switch

Turn signal lights are used when turning left/right or changing lane.

Turn ignition switch to "ON", and slide the turn signal switch to left or right. Then, the turn signal lights will flash.

To release, simply return the turn signal light button to the original position.



Right-side turn signal light flashing means you intend to make a right turn.



Left-side turn signal light flashing means you intend to make a left turn.

### SAFETY HELMET HOOK

- Open the seat, and hook the safety helmet chin belt onto the hook, and then lock the seat.



#### WARNING:

- Never hang your safety helmet on the helmet hook while riding. Doing so could interfere with your riding safety and could damage the scooter.

### SEAT LOCK

#### • Unlock:

Insert the ignition switch key to the seat lock and turn to left to unlock.

#### • Lock:

Press the seat down and it will be locked automatically.

After the seat has been locked, check to make sure it has been locked properly by lightly lifting the seat.



#### CAUTION:

- Do not put the scooter key in the luggage box compartment after seat has been unlocked. This will prevent the key from being locked inside the luggage compartment if the seat should be unintentionally closed.
- Be sure to remove the key after the seat has been locked.

### LUGGAGE BOX

- This box is located under the seat.
- Maximum load capacity: 10kg.
- Do not store valuables in the box.
- Please make sure that seat cushion had been locked completely after it was down.
- Take out valuables before washing to avoid wetting these objects.
- Do not place thermal sensitive objects in the box because of engine's heat and high temperature.

## 7. USE OF EACH COMPONENT

### FUEL TANK CAP 【Fuel refilling】

1. Insert ignition switch key into the lock on the fuel tank cap, and turn the key to the left, then the cap can be removed.
2. Do not fill over the fuel upper limit when refueling.
3. Align the “ ” mark on the cap to the right or left, and turn the key to the right cap in parallel until the cap is locked. Remove the ignition key.



#### **⚠ WARNING:**

- Use caution when refueling! **Keep lit cigarettes and other flames away from the scooter and fuel source!**
- To refuel: 1) Shut off engine, 2) Set scooter up on main stand, 3) Open fuel tank cap, 4) Fill fuel tank.
- Do not fill fuel tank above upper limit of fuel tank when refueling. If fuel tank is overfilled, fuel will flow out through a hole on the fuel tank cap. This could result in a fire and/or damage to the scooter.
- Make sure the fuel tank cap has been properly tightened after refueling and before riding the scooter.
- Do not spill fuel on exhaust pipe as it may ignite and cause a fire, and resulting injury.

### BRAKE

- Use front and rear wheel brakes simultaneously when braking.
- Avoid unnecessary sudden braking as this may lead to the wheels locking and the scooter going out of control.
- Using only the front brake or the rear brake increases the risk of falling because the scooter is tend to pulled to one side.
- Avoid applying the brakes continuously for a long period of time because that may overheat the brakes and reduce its braking efficiency.
- Slow down and brake early when riding in rainy days on slippery roads. Never apply the brakes suddenly to prevent skidding and falling.

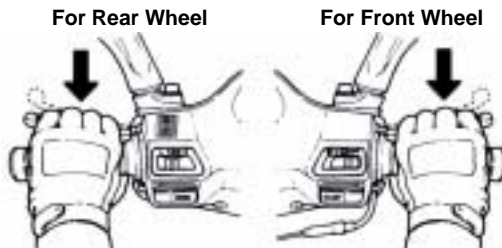

### 《Engine Brake》

Return the throttle valve handle back to its original position, and apply engine brake.

It is necessary to apply both brake and engine brake intermittently when riding on a long or stiff slope.

## 8. IMPORTANT POINTS AND CAUTIONS FOR STARTING ENGINE

### CAUTION:

- Check that the engine and fuel volumes are at adequate levels before starting the engine.
- When starting the engine the main stand must be firmly on the ground and the rear brake must be engaged. This will prevent the scooter from suddenly jerking forward.

Turn ignition switch key to the "ON" position.

1. Apply rear wheel brake.

2. Do not accelerate, press starter button when the brake is applied.

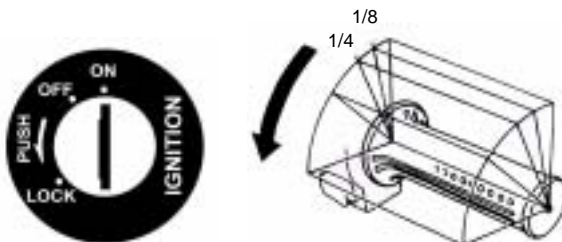

**[We care for you! Before drive off, keep the hand brake applied on the rear wheel.]**

### CAUTION:

- If the engine does not start after the starter button has been pressed for 3–5 seconds rotate the throttle 1/8<sup>th</sup> to 1/4<sup>th</sup> open and press the starter button again.
- To avoid damage the starter, do not continuously press the starter button for more than 15 seconds.
- It is harder to start the engine after the scooter has not been used for a long period of time or after the fuel tank has been run dry. In these situations it may be necessary to press the starter button several times. When doing so keep the throttle in the closed position.
- The engine may need several minutes to warm up if the scooter has not been used for a long period of time.
- Exhaust contains harmful gas (CO), always start the engine in a well ventilated area.

### **[When starting engine with kick starting lever ]**

- Turn the main switch to ON, press the starting lever forcefully by foot with the throttle valve handle in the closed position.
- If engine is difficult to start with the starting lever when the engine is cold, rotating the throttle valve 1/8–1/4 turns should make the scooter start easier.
- Return the starting lever back to its original position after the engine has been started.

### CAUTION:

- When starting the scooter with the kick starter lever, the main stand must be firmly on the ground and the rear brake handle must be engaged.
- Periodically starting the engine with the kick starter lever will keep the kick starter lever in good working condition.

## 9. THE BEST WAY TO RIDE OFF

- Turn on the turn signal light before moving, and make sure no vehicle is coming from behind. Then, ride off.

### THE CONTROL OF THROTTLE VALVE HANDLE

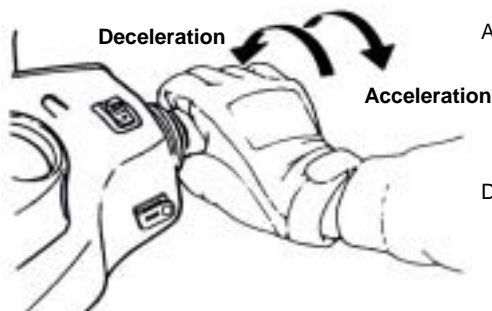

**Acceleration :** To increase speed. When riding on an inclined road, turn the throttle valve handle slowly to allow the engine to output its power.

**Deceleration :** To decrease speed.

### PARKING METHOD

#### • When approaching the parking lot:

1. Turn on the turn signal light early, and pay attention to the vehicles in front, from rear, left and right, then take the inner lane and approach slowly.
2. Return the throttle valve handle back to its original position, and apply brakes in advance. (Brake light comes on when braking to warn drivers of vehicles behind.)

#### • When stopped completely:

1. Press the turn signal switch back to its original position, and turn the ignition switch key to "OFF" position to shut off the engine.
2. Get off the scooter from left side after the engine has been stopped, and select a parking place where the scooter will not interfere with traffic and the ground is level, then put the scooter's main parking stand down.
3. Hold the steering handle with your left hand, and hold down the front end of seat or hold the parking handle on the lower-left side of seat with your right hand.
4. Press the main parking stand with your right foot, put down the main parking stand firmly on the ground.



#### To remind you:

- Lock the steering handle and remove the key after parking to prevent the scooter from being stolen.



#### CAUTION:

- Always park your scooter in a safe place where it will not interfere with traffic.

## 10. INSPECTION AND MAINTENANCE BEFORE RIDING

(Please refer to the components location diagram for the following components.)

### ROUTINE INSPECTION

Check Items		Check Key Points
Engine Oil		Is there enough engine oil?
Fuel		Is it enough? Is it Octane 90 or above
Brake	Front	Braking condition? (Brake lever free play: 10~20mm)
	Rear	Braking condition? (Brake lever free play: 10~20mm)
Tires	Front	Is tire pressure normal? (Standard: 1.75kg/cm <sup>2</sup> )
	Rear	Is tire pressure normal? (Standard: 2.25 kg/cm <sup>2</sup> for 1 person, 2.5 kg/cm <sup>2</sup> for 2 persons)
Steering Handle		Does the handle vibrate abnormally or is difficult to turn?
Speedometer, lights, and rearview mirror		Is it operated properly? Do lights come on? Can it be seen clearly from behind?
Tightness of Main Components		Are screws, nuts loosen?
Abnormal Points		Do the previous troubles still exist?

### ⚠ CAUTION:

- If any problems are found during routine inspections always correct them before riding the scooter. If necessary, have the scooter inspected and repaired by an Authorized SANYANG dealer.

### ENGINE OIL INSPECTION AND CHANGE

#### INSPECTION:

1. Use the main parking stand to support the motorcycle on a level ground, remove the dipstick after engine stopped for 3~5 minutes. Wipe oil off the dipstick and then insert it into the guide tube again (Do not rotate it.)
2. Remove the dipstick and check whether oil level is in between the upper and lower marks.

**Add oil to upper limit if oil is under the lower limit. (Check cylinder, crankcase...etc for leakage.)**

#### OIL CHANGE:

- Change engine oil after the first 300km, and change the engine oil every 1000km thereafter. Clean oil filter after the first 300km, and clean oil filter every 6,000km.
- In order to maintain the engine's maximum performance, check whether the engine oil is enough every 500km. Add oil to upper limit if the engine oil has been found to be inadequate.
- Engine Oil : Use API SH, SAE 10w-30 grade or better engine oil. Otherwise, damage will not be covered by warranty.

Recommended Oil: **SYM Genuine EXTRA 4X OIL.**

- Oil Capacity : 1.0 Liter (0.8 liters for routine change),  
oil filter change: 0.8 liters.

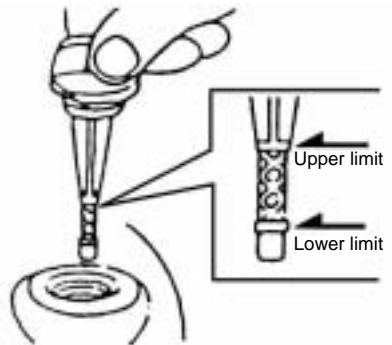

## 10. INSPECTION AND MAINTENANCE BEFORE RIDING

---



### 【Oil Filter Cleaning】

Open the filter nut assembly of the element, and remove the element. Remove the foreign materials from the element by using a gasoline or air spraying gun.

#### **WARNING:**

- Oil level will not be correct when checking the oil level with the motorcycle parked on an unlevelled ground or immediately after the engine stopped.
- Engine and exhaust pipe are hot right after engine stopped. Pay special attention not to get burned when checking or replacing engine oil.

#### **INSPECTION OF FUEL LEVEL** (Note: "Inspection" was previously misspelled)

- Firmly support the scooter with its main stand on a leveled ground, turn the main switch to "ON" position, check if the fuel meter needle moves.
- Fuel gauge may be defective or electric circuit disconnected if there is some fuel in the tank, but the needle does not move. Please ride slowly to **an authorized service station** to have your scooter checked.

#### **CAUTION:**

- Do not check the fuel level or refuel while the engine is running. It is not necessary to start engine to check the fuel level.
- Make sure fuel cap on tank is closed tightly before riding scooter.
- Do not run engine in an enclosed space. Ensure proper ventilation as exhaust fumes may be dangerous and over exposure to same may result in illness, injury or death.
- There is a danger of fire and explosion when handling fuel. Never refuel in an enclosed space.
- Do not over fill the fuel tank.
- Do not spill fuel onto hot engine or related parts.

#### **TRANSMISSION OIL INSPECTION AND CHANGE**

##### **INSPECTION:**

- Use the main stand to support the scooter on a level ground, after the engine stops, wait for 3~5 minutes or until all engine parts have cooled. Remove the transmission oil infusion bolt, put a measuring glass under the drain bolt, and remove the drain bolt. Let the oil flows into measuring glass and check for decreased or not. (at disassembly: 110 c.c. / at change: 90~100 c.c.).

##### **OIL REPLACEMENT:**

- Stop the engine and use the main stand to support your scooter on a level ground. Remove the infusion bolt and drain bolt, drain out the oil.
- Install the drain bolt and tighten it. Fill new transmission oil (90~100 c.c.), and install the infusion bolt and tighten it. (make sure that bolts are tightened and check that there's no leakage.)

Recommend Oil: Genuine SYM HYPOID GEAR OIL (SAE 85W-140).

## 10. INSPECTION AND MAINTENANCE BEFORE RIDING

### INSPECTION AND ADJUSTMENT OF BRAKE FREE PLAY

**INSPECTION:** (Brake lever free play must be checked with the engine shut off.)

- Brake lever free play for front and rear wheels.
- When checking the hand-braking lever for front and rear wheels, its free play (the stroke of hand-braking lever from no braking to initial braking) should be 10~20mm.
- It is abnormal if the feel is spongy when holding the hand-braking lever forcefully.
- Never attempt to adjust brakes unless you know what you are doing. Otherwise, have a properly trained mechanic adjust brakes. Never operate the scooter if effective braking is questionable.

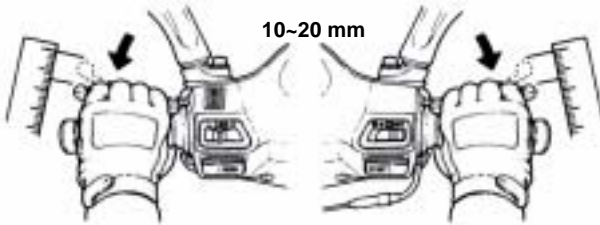

**ADJUSTMENT:** ( Rear wheel drum type )

- The indentation of brake adjustment nut must be aligned with the pin. (see below figure)

Adjustment nut

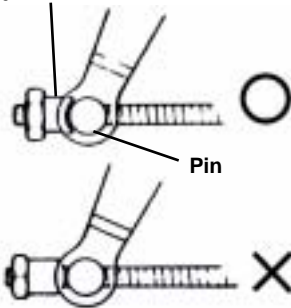

#### CAUTION:

- Adjust the brake lever “Free Play” when the “Free Play” is between 10~20 mm. Check to brake indicators on both the front and rear wheels. If the arrow on the brake arm is aligned with the “ ” mark on the brake panel, the brake lining has been excessively worn and must be replaced immediately.

- Turn the adjustment nut on brake arm of front and rear wheels to adjust the free play of hand-brake lever.
- Hold the hand-brake levers after adjusting with both hands until there is effective brake feeling.
- Measure the free play with a rule.

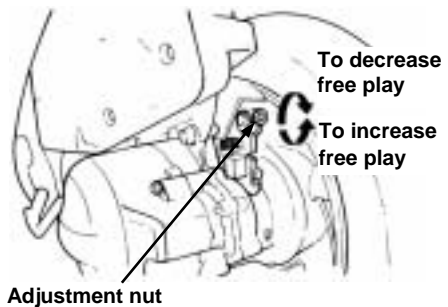

## 10. INSPECTION AND MAINTENANCE BEFORE RIDING

### **DISK BRAKE INSPECTION** (Applicable for model equipped with disc brake.)

(Leak, damaged, looseness of brake line)

- Visual Inspection for leakage or damage. If there is any, take your scooter to SYM Authorized Dealer or Franchised Dealer for a check or repair. Do not operate the scooter in this condition until the problem has been resolved.

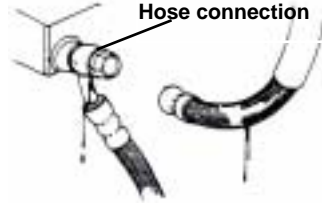

#### **CAUTION:**

- Please drive your motorcycle on a dry road surface slowly and operate front and rear brakes in order to find out if there is any malfunction so as to ensure the motorcycle is at its optimum condition and safe to ride.

#### ( Checking front brake lining )

- Check the brake from behind the brake caliper. The brake pad must be replaced with new lining when the brake pad wear limit reaches the brake disk.

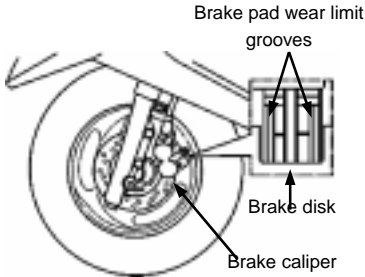

#### ( Checking oil quantity in brake oil reservoir )

- Park the motorcycle on a level ground, and check if fluid level is under the "LOWER" mark. Recommended Brake Fluid: WELL RUN BRAKE OIL (DOT 3).



#### ( Replenishment of front wheel brake fluid )

1. Loosen the screws and remove the master cylinder cover.
2. Wipe clean foreign materials, dirt around the reservoir, being careful not to let foreign materials fall into the reservoir.
3. Remove the diaphragm plate and the diaphragm.
4. Add brake fluid to upper level.
5. Install the diaphragm plate and the diaphragm, and install the master cylinder cover.
6. Please note the diaphragm direction, and do not let foreign materials fall into the reservoir. And tighten the master cylinder cover securely.

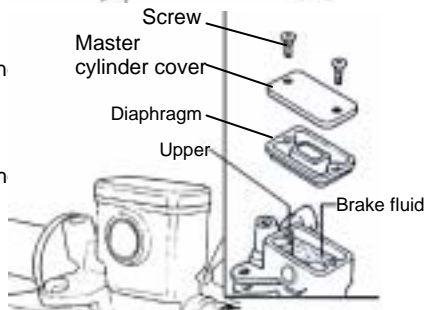

#### **CAUTION:**

- To prevent chemical reaction, please do not use brake fluids other than those recommended.
- Do not fill above the upper limit when adding brake fluid and avoid dropping on painting or plastic components to prevent damage.

## 10. INSPECTION AND MAINTENANCE BEFORE RIDING

### THROTTLE VALVE HANDLE CLEARANCE ADJUSTMENT

- Correct clearance allows throttle valve handle to rotate 2~6mm.
- To adjust, first loosen the fixing nut, then turn the adjusting nut to the proper position and securely tighten the fixing nut.

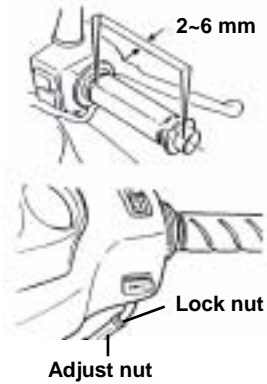

#### Throttle Valve Check Items:

- Check throttle valve cable to see if it can be moved smoothly from a closed position to a wide open position.
- Rotate steering handle from side to side to check that the throttle cable is not interfered with.
- Check to see if the throttle cable is obstructed by any other cables preventing it from being operated smoothly.

### TIRE INSPECTION

- Tires should be checked and inflated with the engine shut off.
- If a tire's ground contacting curve is abnormal, check it with an air pressure gauge and inflate it to the specified pressure to meet applicable standard before riding.
- Tires pressure must be checked when the tire is cool.

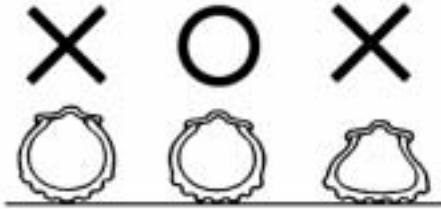

PLEASE REFER TO SPECIFICATIONS FOR STANDARD TIRE PRESSURE

- Visual check tires for frontal and lateral side walls for crack or damage.
- Visual check tires for any nails or small stones wedged in the tread.
- Check the "tread wear indicator" condition to see if tread groove depth is insufficient.
- A tire with a wear bar showing is worn out and should be replaced immediately.

Foreign materials (nails or small stones)

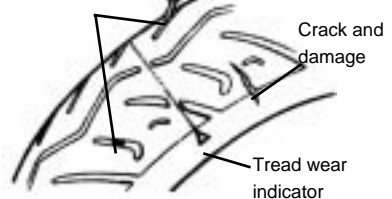

#### WARNING:

- Inspect the scooter's tires regularly. Over inflated, under inflated, old, worn or cracked tires can adversely affect the way the scooter handles and could lead to sudden tire failure. Sudden tire failure could cause you to lose control of the scooter which could cause an accident and could lead to injury or death.
- Only ride the scooter with properly inflated tires. Always replace old, worn or cracked tires.

## 10. INSPECTION AND MAINTENANCE BEFORE RIDING

### STEERING HANDLE FRONT SHOCK ABSORBERS INSPECTION

- Perform this check with engine shut off and ignition switch key removed.
- Visual check front shock absorbers for damage.
- Operate steering handle up and down, and check front shock absorbers for noises due to bends.
- Check the bolts and nuts of front shock absorbers with wrenches for tightness.
- Shake steering handle up & down, left & right, and front & rear to check if it is loosen, has too much resistance and pulls to one side.
- Check steering handle if it is being pulled too tight by the brake cables.
- Take your scooter to SYM Authorized Dealer or Franchised Dealer for a check or adjustment if any abnormal conditions are found.

**【Figures on the right are for operation checks only】**



### REAR CUSHION HARDNESS SETTING

The rear cushion is 5 stage adjustable type. It's set at 3<sup>rd</sup> stage when manufactured, and you can adjust it depending on your need. Turn the adjust collar of the cushion to adjust it's hardness.

**⚠ CAUTION:**

- Turn counterclockwise to harden it, and turn clockwise to soften it.
- Mark sure adjust both cushion at the same time to be sure the riding stability.



### CHECKING FOR FUEL LEAKAGE

- Check fuel tank, fuel hoses, and carburetor...etc. for leakage.

### CHECING THE LUBRICATION OF BODY'S VARIOUS MECHANISMS

- Check the body's pivot points if they have enough lubrication.  
(For example, the pivot points on the main stand, the side stand, and the brake lever...etc.)

## 10. INSPECTION AND MAINTENANCE BEFORE RIDING

### INSPECTION AND MAINTENANCE OF BATTERY

- This scooter is equipped with a maintenance-free type battery, so it is unnecessary to check or electrolyte. Have your scooter checked by SYM Authorized Dealer or Franchised Dealer should any abnormality be found.
- Remove the battery terminals and clean if there is dirt or corrosion on them.

#### NOTICE:

##### Battery removal procedures are as follows:

- First turn ignition switch "OFF," then remove the negative cable screw and disconnect the negative cable, then remove the positive cable screw and positive cable and remove battery.
- To install the battery, reverse the procedures of the removal of the battery.

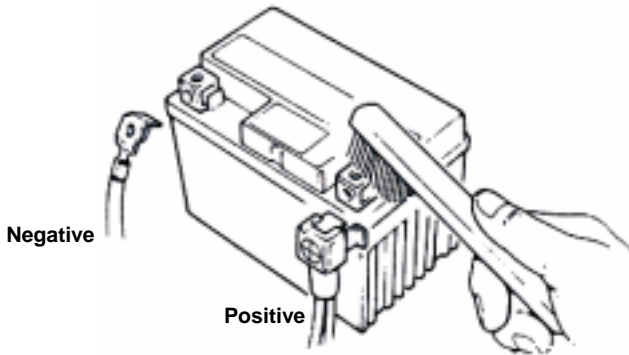

#### CAUTION:

- Keep the scooter's battery clean. If the battery's posts are corroded and/or are covered with white powder clean them with warm water.
- If there is obvious corrosion on the battery terminals, disconnect the battery cables and remove the corrosion with a steel brush.
- If the battery needs to be replaced, replace with a same closed-type battery (Maintenance-Free).

#### CAUTION:

- This scooter uses a sealed type (Maintenance-Free) battery; never remove the battery caps.
- In order to prevent electrical leakage and self-discharge when the battery sits idle for long periods of time, remove the battery from scooter and store it in a well-ventilated and dimly lighted area. Store battery out of reach of children. If the battery is to be kept on the scooter, disconnect the battery's negative cable.
- Replace the battery cables after cleaning and apply a thin coat of grease to the battery terminals when reconnecting the same.

## 10. INSPECTION AND MAINTENANCE BEFORE RIDING

### CHECKING AND CHANGING FUSES

Fuse box is on the frame body, remove the luggage box then you can see the fuse box is on the frame body right side. Turn off ignition switch, and check fuses if they are intact. Replace the blown fuse with a new one having the same specified amperage rating (20A or 15A or 10A). Using a fuse which the amperes is larger than specification, a brass or iron wire to replace a blown fuse is strictly prohibited to avoid damaging the electrical system and the circuit.

- Remove the storage box, and you'll find the fuse box near light.
- Open the fuse box cover, and pull out the fuse. Check it for damage or broken.
- Fuses must be firmly secured with wire connectors when replacing. Loose connections will result in overhead and damage.
- Use only parts having the specified specification to replace electrical components such as light bulbs. Using parts not having the specified specifications for replacement may cause the fuse to blow and over-discharge the battery.
- Avoid spraying water directly on or around fuse box when washing the scooter.
- Take your scooter to your dealer for an inspection if a fuse is blown by unknown causes.

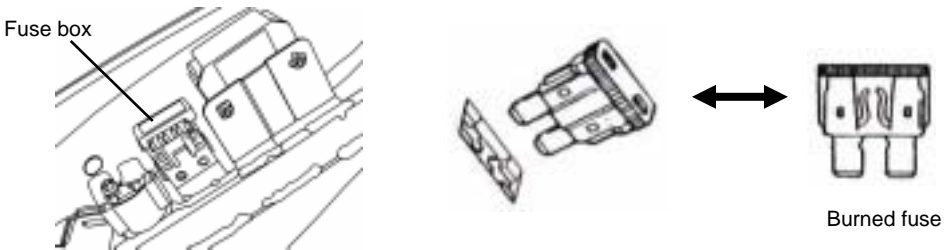

### CHECKING THE TURN SIGNAL LIGHTS AND HORN

- Turn the ignition switch key to "ON" position.
- Turn on the turn signal light switch, and make sure that the front & rear and left & right signal lights flashes and also check if the warning buzzer sounds.
- Check turn signal light covers if they are dirty, crack, or loosen.
- Press horn button to check if it works.

#### CAUTION:

- Use only specified bulbs for turn signal lights. Otherwise, the normal operation of turn signal lights will be affected.
- Switch on the turn signal before changing lanes or marking a turn to inform others of your intent.
- After changing lanes or making a turn, switch of turn signal immediately by pressing the reset button. This button is located in the center of the turn signal switch.

### CHECKING THE HEADLIGHT AND TAIL LIGHT

- Start engine and turn on the headlight switch. Check if headlight and tail light come on.
- Check the brightness and direction of headlight by wall to see if it is correct.
- Check the headlight cover if it is dirty, crack, or loosen.

## 10. INSPECTION AND MAINTENANCE BEFORE RIDING

### CHECKING THE BRAKE LIGHT

- Turn the ignition switch key to "ON" position, hold the hand-braking levers for front and rear wheels. Check if the brake lights come on.
- Check the brake light cover if it is dirty, crack, or loosen.

#### CAUTION:

- Use only SANYANG specified bulbs, do not use bulbs with different specifications to avoid damaging electrical system, burning out bulbs, and discharging the battery.
- Do not modify or add other electrical components to your scooter. This may prevent an over load or short circuit which may result in a fire in some cases.

### CHECKING THE SPARK PLUG

- Remove the cap of spark plug cable (remove the spark plug using the spark plug wrench in the tool kit.
- Check the electrode if it is dirty or fouled by carbon deposits.
- Remove the carbon deposits on the electrode with steel wire, and clean the spark plug with gasoline, then, wipe dry with a rag.
- Check the electrode, and adjust its gap to 0.8 mm.  
(Check it with a feeler gauge)
- Hand tight the spark plug as far as it can go and then tighten it another 1/2~3/4 turns with a wrench.

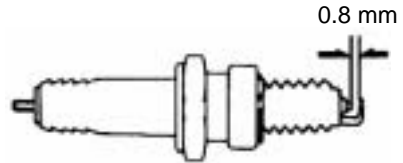

#### WARNING:

- The engine is extremely hot after running. Allow scooter to cool completely before removing the spark plug to avoid being burned or other possible injury.  
Use only spark plugs suitable for the engine specifications of this motorcycle recommended by the manufacturer. (Refer to specifications.)

### A reference table for anti-freeze concentration percentages under different temperatures

1. Radiator anti-freeze specification for this scooter is H68. (SYM Bramax radiator agent)
2. Proper anti-freeze percentages for different frozen temperatures are as follows:

Anti-freeze percentage	Frozen temperature	Remark
20%	-8	50% concentration is used for all scooters before delivery to ensure the effectiveness of anti-freeze.
30%	-15	
40%	-24	
50%	-36	

3. If the specified anti-freeze is unavailable, use an equivalent with the same high quality.
4. Increase radiator maintenance intervals when the weather is extremely cold.

## 10. INSPECTION AND MAINTENANCE BEFORE RIDING

### COOLING SYSTEM INSPECTION

(Checking coolant lever)

1. Support vehicle with main stand on a level ground.
2. Check reserved tank from viewing window to see if coolant level is between the upper limit and lower limit mark.
3. Add coolant up to upper mark if coolant is close to the lower mark.

(Check the cooling system for leakage)

- Check radiator and piping for leakage.
- Check the ground where the vehicle is parked for water dripped from the vehicle.

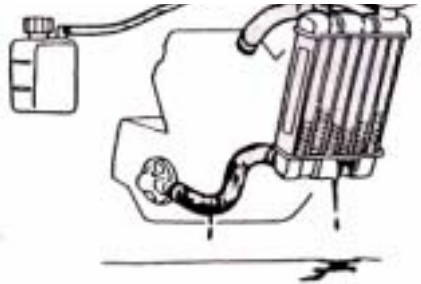
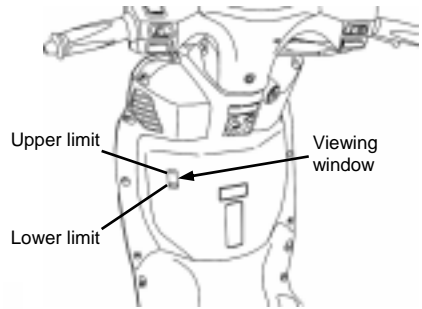

### REPLENISHMENT OF COOLANT

Always keep radiator cap tightly closed.

1. Support vehicle on a level ground in a straight up position.
  2. Remove the front cover.
  3. Open reserved tank cap, refill coolant until reaches the upper limit.
- If coolant level becomes too low and occurs too often, it may indicate there is something wrong with the coolant system.
  - To avoid radiator getting rusty, do not use coolants other than those recommended.

**Coolant recommended: SYM Bramax radiator agent**

**Concentration: 50%**

**Radiator capacity: Main radiator : 780 c.c.**

**Reserved tank : 420 c.c.**

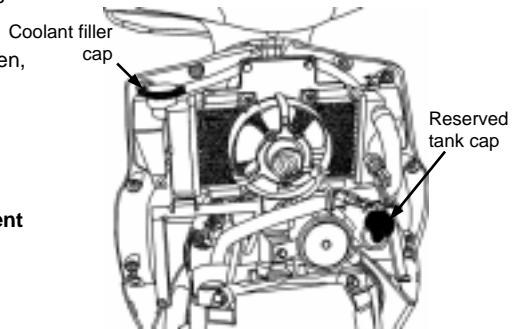

#### CAUTION:

- Use soft water when mixing coolant.
- Please pay special attention that using poor quality coolant may shorten the service life of the radiator.
- Coolant should be changed once a year normally.

#### CAUTION:

- Please refer to a table showing what percentage of anti-freeze should be used under different temperatures if the vehicle is to be operated in the low temperature areas. (below 0 )

## 10. INSPECTION AND MAINTENANCE BEFORE RIDING

### CHECKING THE AIR CLEANER

#### 《DISASSEMBLE PRCEDURE》

1. Remove mounting screws from air cleaner cover.
2. Remove the air cleaner cover, then remove filter element.
3. Take the element out and clean it. (Refer to maintenance schedule.)

#### 《ASSEMBLE PRCEDURE》

- Assemble the air cleaner in reverse order of disassemble.

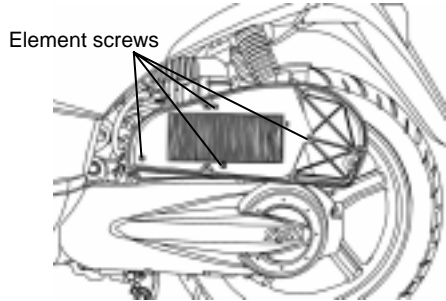
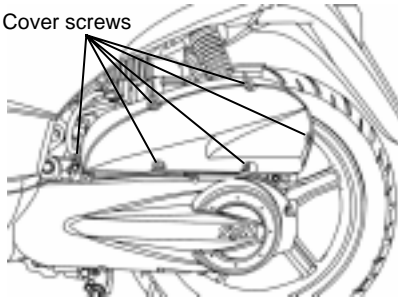

#### CAUTION:

- Dust deposit is one of the major causes of reducing output horsepower and increasing fuel consumption.
- Change the air cleaner element more frequently to prolong the engine's service life if the scooter is driven on dusty roads very often.
- If air cleaner is installed improperly, dust will be absorbed into cylinders, which may cause a premature wear and reducing output power and engine life.
- Be careful not to soak the air cleaner when washing the scooter. Otherwise, it will cause engine hard to start.

## 11. WHEN THERE IS AN ABNORMAL CONDITION OR A TROUBLE

### DIAGNOSIS WHEN ENGINE DOES NOT START



For Rear Wheel      For Front Wheel



(1). Has the ignition switch key been turned to "ON" position?

(2). Is there enough fuel in the fuel tank?

(3). Is the rear or front wheel brakes applied when pressing starting button?

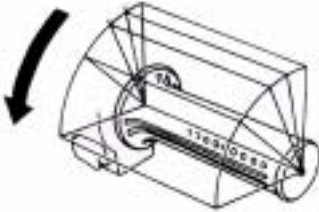

(4). Do you rotate the throttle valve handle while pressing starting the button?

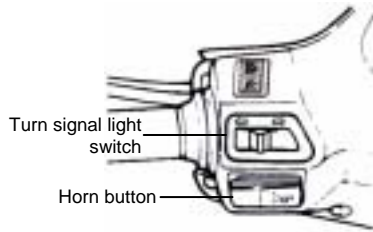

(5). Turn the ignition switch key "ON", and press horn button down, if the horn does not sound, the fuse may have been blown.

【Have your scooter checked by SYM authorized dealer or franchised dealer immediately if there are no problems with the above items and engine still can not be started.】

## 12. C.D.I. ELECTRICAL IGNITION SYSTEM

The charge and discharge principle of a condenser is adopted for the C.D.I system to supply electrical energy created by generator's coil, to the ignition coil in accordance with specified ignition timing so that the spark plug may generate sparks as required.

## 13. SUGGESTIONS ON ENGINE FUEL

- This scooter is designed to use UNLEADED gasoline of Octane No. 90 or higher.
- If the scooter is operated in high altitude (where the atmosphere pressure is lower), it is suggested that the air/fuel ratio should be readjusted to maximize the engine performance.

## 14. TRANSMISSION OIL

- Recommended Oil: Genuine SYM HYPOID GEAR OIL (SAE 85W-140)

## 15. CAUTIONS FOR RIDING SCOOTER

---

1. Raise the scooter with the main stand, and sit on the seat.  
Push the scooter forwarding to raise the main parking stand.



**CAUTION:**

Never rotate the throttle valve handle at will to increase the engine RPM before riding off.

2. Get on the scooter from the left side, and sit on the seat properly, keep your feet firmly on the ground to prevent the scooter from falling.



**CAUTION:**

Apply brake on the rear wheel before riding off.

3. Rotate the throttle valve handle slowly, and then the scooter will begin to move.



**CAUTION:**

- Rapidly rotate the throttle valve handle may cause the scooter moving forward suddenly and it is very dangerous.
- Make sure the side parking stand is spring back completely before riding off.

**【Do not use the brake suddenly and make a sharp turn】**

- Rapid braking and sharp turning will cause slip and fall.
- Rapid braking or sharp turning will cause slipping, lateral slipping, or fall especially in rainy days when the road is wet and slippery.

**【Drive with extreme caution during rainy days】**

- The brake distance in rain day or on wet road will longer than that on a dry road. Therefore, slow down and prepare to apply the brake earlier.
- The throttle valve handle should be released, and the brakes should be properly applied as it is needed while reducing the speed when going down a slope.

## 16. PERIODICAL MAINTENANCE SCHEDULE

Item	Maintenance kilometer	300KM	Every 1000KM	Every 3000KM	Every 6000KM	Every 12000KM	Remarks
	Check Items	Maintenance Interval	NEW	1 Month	3 Months	6 Months	
1	Air cleaner element(Remark)	I		C	R		
2	Oil filter(Screen)	C			C		
3	Engine oil	R	I	Replacement for every 3000KM			
4	Tire, pressure	I	I				
5	Battery	I	I				
6	Spark plug	I		I		R	
7	Carburetor(idle speed)	I			I		
8	Steering bearing and handles	I		I			
9	Check Transmission for leakage	I	I				
10	Check crankcase for leakage	I	I				
11	Transmission Oil	R	Replacement for every 5000KM(5 Months)				
12	Drive Belt/roller				I	R	
13	Fuel tank switch and lines	I		I			
14	Throttle valve operation and cable	I	I				
15	Engine bolts and nuts	I		I			
16	Cylinder head, cylinder, and piston				I		
17	Exhaust system/cleaning carbon				I		
18	Cam Chain/ignition time	I		I			
19	Valve clearance	I			I		
20	Shock absorbers	I			I		
21	Front/rear suspension	I			I		
22	Main/side stands	I			I/L		
23	Crankcase Blow-by system(PCV)	I		I			
24	Coolant	I	I			R	
25	Cooling fan, lines	I	I				
26	Clutch disk				I		
27	Brake mechanism/brake lining (pad)	I	I				
28	Bolts/nuts for each components	I	I				

The above maintenance schedule is established by taking the monthly 1000 kilometers as a reference which ever comes first.

Have your motorcycle checked and adjusted periodically by your SYM Authorized Dealer or Franchised Dealer to maintain the motorcycle at the optimum condition.

Code: I ~ Inspection, cleaning, and adjustment R ~ Replacement

C ~ Cleaning (replaced if necessary) L ~ Lubrication

Remark: 1. Clean or replace the air cleaner element more often when the motorcycle is operated on dusty roads or in the Heavily- polluted environment.

2. Maintenance should be performed more often if the motorcycle is frequently operated in high speed and after the motorcycle has accumulated a higher mileage.

【Notes in the remarks are used to indicate the applicable models.】

## 17. SPECIFICATION

Item	Model	LH18W	LH12W
	Specification		
length		2064 mm	
width		706 mm	
Height		1165 mm	
Wheel base		1385 mm	
Net Weight		135 kg	
Type		4- stroke 4V single cylinder engine	
Fuel		UNLEADED(OCTANE 90 OR HIGHER)	
Cooling type		Water-cooled	
Displacement		171.2	124.5 cc
Compression ratio		10.8:1	10.5:1
Max. HP		15.5 ps / 8000 rpm	12.5 ps / 8500 rpm
Max. torque		1.57 kg-m / 6500 rpm	1.11 kg-m / 6500 rpm
Starting methods		Electrical	
Front shock absorber		TELESCOPE	
Rear shock absorber		UNIT SWING	
Clutch / Transmission		Centrifugal type / CVT	
Front tire		100 / 80-16 50P	
Rear tire		120 / 80-16 60P	
Wheel		Aluminum alloy	
Tire pressure		Front: STD 1.75kg/cm <sup>2</sup> , Rear: STD 2.25 kg/cm <sup>2</sup> for 1 person, 2.5 kg/cm <sup>2</sup> for 2 person	
Front brake / Rear brake		Disc type (Ø 220 mm) / Drum type (Ø 130 mm)	
Front light bulb(high, low)		12V 55W / 60W x 1	
Brake light bulb(tail light)		12V 5W / 21W x 1	
License light bulb		12V 5W x 1	
Position lamp bulbs		12V 5W x 2	
Turn signal light bulbs		12V 10W x 4	
Gauge illume bulbs		12V 3.4W x 2	
Gauge pilot bulbs		12V 1.7W x 3	
Engine oil capacity		1.0 L (0.8 L for change)	
Transmission oil capacity		110 c. c. (100 c. c. for change)	
Fuel tank capacity		8.0 L	
Fuse		20Ax1, 15Ax2, 10Ax1	
Spark plug		NGK CR 8E	
Battery capacity		12V 8Ah (closed type, maintenance-free battery)	
Air cleaner		Paper type	
Fuel tank cap		Open lock type	
Front light		General type (single)	
Rear grab frame		Can load cargo (maximum load : 5kg)	